

Product Change Notice (PCN)

Date: 08/02/2024

PCN Number: PCN-0455153R-01

To Our Customers:

We appreciate your use of our products. Our commitment in maintaining and improving processes is demonstrated by plans to enhance our product quality, reliability, and manufacturability. The purpose of this notice is to inform you of a product change.

Product(s) Affected: PJ-018H-SMT-TR

Reason(s) for Change: *Manufacturing Improvement processes*

Description of Change: *Product re-engineered for improved manufacturability and production yield. Increased Center Pin length & Plating Difference. See image below for reference and check CUI Devices website for updated drawing. Cosmetic differences may be visible but will not affect the form fit and function of the product.*

OLD

5.6mm Center pin, Silver Plated

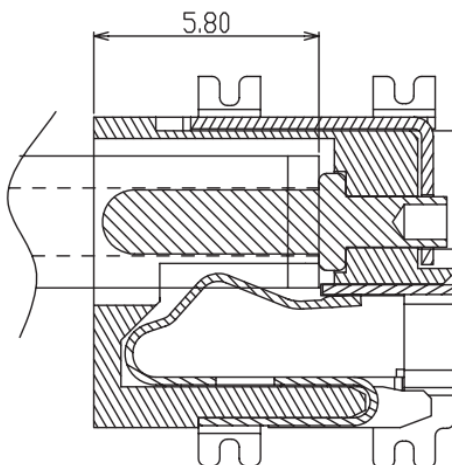

DESCRIPTION	MATERIAL	PLATING/COLOR
center pin	H62	silver
terminal 1	brass t=0.30	silver
terminal 2	C5210R-EH t=0.20	silver
terminal 3	brass t=0.25	silver
housing	PA9T (UL94V-0)	black

F-723-001

Revision: A

NEW

6.2mm Center pin, Nickel Plated

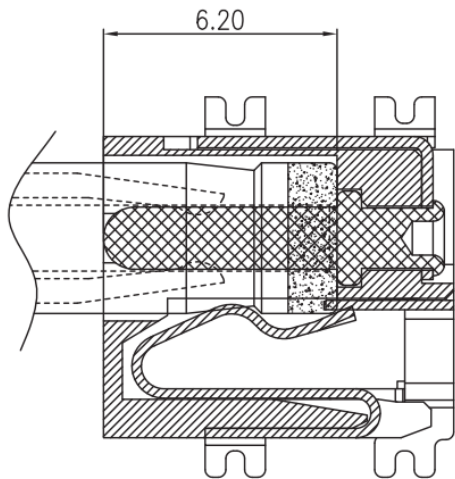

DESCRIPTION	MATERIAL	PLATING/COLOR
center pin	H62	nickel
terminal 1	brass t=0.30	silver
terminal 2	C5210R-EH t=0.25	silver
terminal 3	brass t=0.25	silver
housing	PA9T (UL94V-0)	black

Affected Date Code: All orders placed after **07/25/2024**.

Product Availability: *Pertaining to market availability*

PCN Approval:

Operations/Quality



Product Management



F-723-001

Revision: A