

Product Change Notice (PCN)

Date: 11/22/2019

PCN Number: PCN-0450594R-01

To Our Customers:

We appreciate your use of CUI Devices products. Our commitment in maintaining and improving processes is demonstrated by plans to enhance our product quality, reliability and manufacturability. The purpose of this notice is to inform you of a product change.

Product(s) Affected: MD-CV series (part numbers MD-40CV, MD-60CV, MD-80CV).

Reason(s) for Change: Manufacturing build location change.

Description of Change: minor dimensional changes, such as pin length, and materials changes as shown below. Nut change from metal to plastic.

Old Design

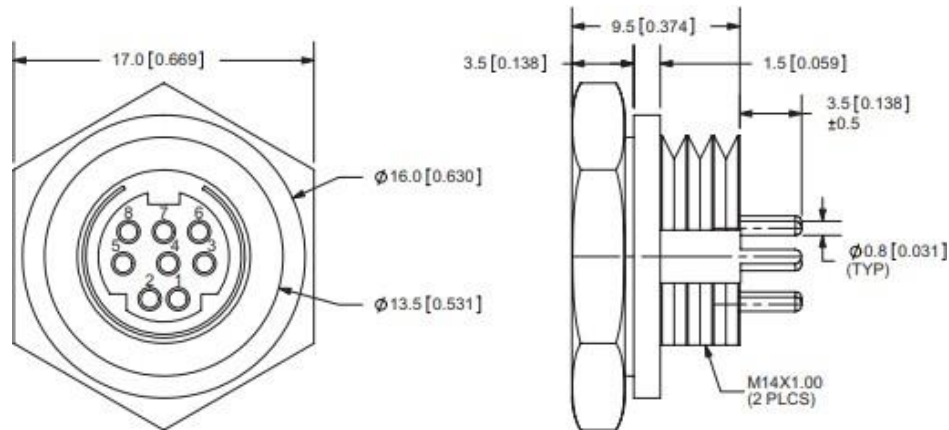

New Design

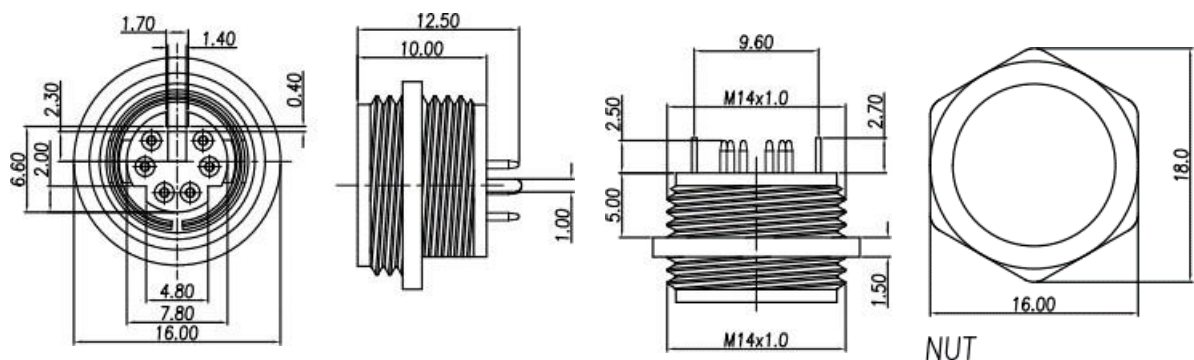

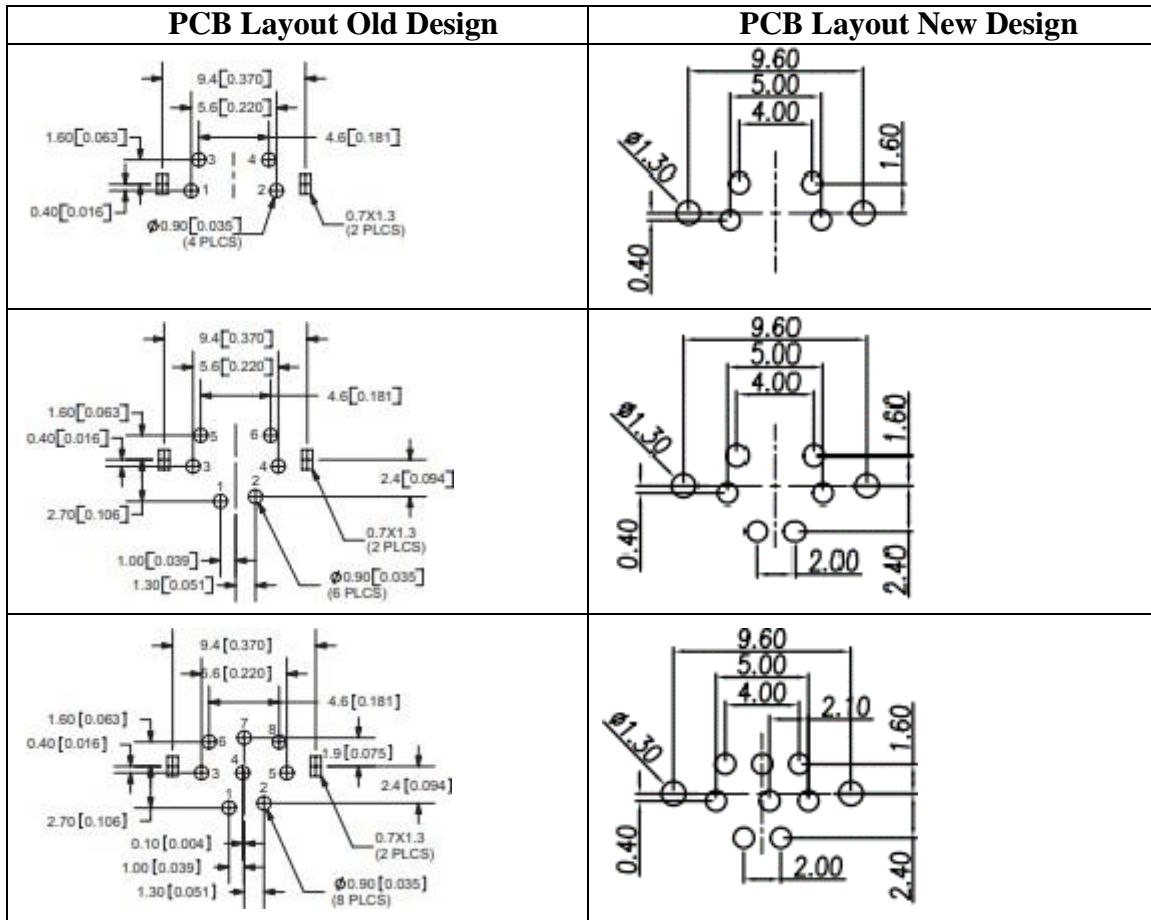

Old design materials

	MATERIAL	PLATING
earth terminal	brass	tin
terminal contacts (1~8)	phosphor bronze	silver
housing	PBT	

New design materials

	MATERIAL	PLATING
earth terminal	brass	nickel
terminal contacts (1~8)	phosphor bronze	tin
housing	PBT (UL94V-0)	black

Affected Date Code: 11/15/19

Product Availability: currently available

CUI DEVICES

20050 SW 112th Ave. Tualatin, Oregon 97062
phone: 800.275.4899 fax: 503.612.2383
www.cuidevices.com

Additional Information: none

PCN Approval:

Operations/Quality



Product Marketing

