

Product Change Notice (PCN)

Date: 08/15/2024

PCN Number: PCN-0381029R-01

To Our Customers:

We appreciate your use of our products. Our commitment in maintaining and improving processes is demonstrated by plans to enhance our product quality, reliability, and manufacturability. The purpose of this notice is to inform you of a product change.

Product(s) Affected: *GF0668*

Reason(s) for Change: *Molding update.*

Description of Change: *SPL increased to 91dB, operating temperature range -20~60°C, brown gasket is now black, dimensional changes shown below:*

Current design

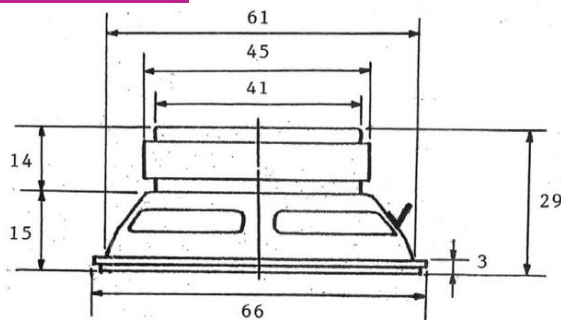

New design

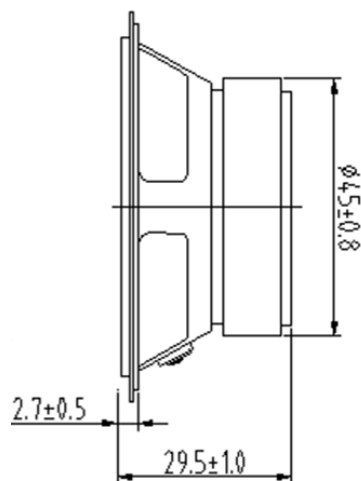

F-723-001

Revision: A



Affected Date Code: *All orders placed after August 1st, 2024.*

Product Availability: *All goods on orders placed after August 1st, 2024.*

PCN Approval:

Operations/Quality

A handwritten signature in black ink, appearing to read "Robert D. Quinn", is written over a horizontal line.

Product Management

A handwritten signature in black ink, appearing to read "Maggie Wilson", is written over a horizontal line.