

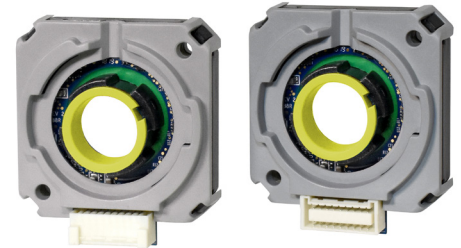

SERIES: AMT24 | **DESCRIPTION:** MODULAR ABSOLUTE ENCODER

FEATURES

- high speed protocol for fast low latency position data
- patented capacitive ASIC technology
- low power consumption
- 12 or 14-bit absolute position with multi-turn capability
- half-duplex RS485 - high speed 2 Mbps or adjustable data rate
- settable zero position
- configuration and programming via AMT Viewpoint™ software
- compact modular package with locking hub for ease of installation
- radial and axial cable connections
- -40 ~ 105°C operating temperature



ELECTRICAL

parameter	conditions/description	min	typ	max	units
power supply	VDD	3.8	5	5.5	V
start-up time ¹			200		ms
current consumption	with unloaded output		16		mA

Note: 1. Encoder must be stationary during start-up.

ABSOLUTE POSITION CHARACTERISTICS

parameter	conditions/description	min	typ	max	units
resolution	12 or 14-bit				
accuracy			0.2		degrees
absolute zero position	settable via AMT Viewpoint™ GUI or RS485 (single-turn versions only)				
multi-turn	multi-turn and single-turn versions available				
turns counter ²	signed binary number		14		bits
absolute position update rate	12-bit 14-bit		25 100		µs µs

Notes: 2. Multi-turn encoders only.

MECHANICAL

parameter	conditions/description	min	typ	max	units
motor shaft length		13.5			mm
motor shaft tolerance			NOM +0/-0.015		mm
weight			26		g
axial play				±0.3	mm
hub set screw to shaft torque	set screw size: M2.5x0.45		3		in-lb
rotational speed at each resolution	12-bit position resolution 14-bit position resolution			8,000 4,000	RPM RPM

ENVIRONMENTAL

parameter	conditions/description	min	typ	max	units
operating temperature		-40		105	°C
humidity	non-condensing			85	%
vibration	10~500 Hz, 5 minute sweep, 2 hours on each XYZ			5	G
shock	3 pulses, 6 ms, 3 on each XYZ			200	G
RoHS	yes				
REACH	EC 1907/2006				

RS485 INTERFACE

parameter	conditions/description	min	typ	max	units
protocol	RS485 balanced digital multi-port interface				
data rate ^{3,4}	8 data bits, no parity, 1 stop bit, asynchronous 2 Mbps 115,200; 38,400; 19,200; 9,600 bps				
transceiver	Texas Instruments THVD1424				
turnaround time	time before encoder responds with position				
	2 Mbps	3			µs
	115,200 bps	10.8			µs
	38,400 bps	30			µs
	19,200 bps	56			µs
9,600 bps	110			µs	
driver differential output voltage magnitude	load resistance = 54 Ω	1.5	2	3.3	V

Notes: 3. Data rate configured with AMT Viewpoint™
4. Default data rate on kits is 2 Mbps.

Checksum

The AMT24 encoder uses a checksum calculation for detecting transmission errors. The upper two bits of every response from the encoder are check bits. Those values are shown in the examples below as K1 and K0. The check bits are odd parity; K1 for the odd bits in the response, and K0 for the even bits in the response. These check bits are not part of the position, but are used to verify its validity. The remaining lower 14 bits are the useful data. Here is an example of how to calculate the checkbits for a 16-bit response, from a 14-bit encoder.

Full response: 0x61AB

14-bit position: 0x21AB (8619 decimal)

Checkbit Formula

Odd: $K1 = !(H5 \oplus H3 \oplus H1 \oplus L7 \oplus L5 \oplus L3 \oplus L1)$

Even: $K0 = !(H4 \oplus H2 \oplus H0 \oplus L6 \oplus L4 \oplus L2 \oplus L0)$

From the above response 0x61AB:

Odd: $0 = !(1 \oplus 0 \oplus 0 \oplus 1 \oplus 1 \oplus 1) = \text{correct}$

Even: $1 = !(0 \oplus 0 \oplus 1 \oplus 0 \oplus 0 \oplus 0 \oplus 1) = \text{correct}$

RS485 INTERFACE (CONTINUED)

Addressing

The AMT24 encoder supports multiple encoders on the RS485 bus. This is accomplished by giving each encoder a unique node address. This node address is 8 bits long but the low two bits must be 0. Therefore, the encoder can have any single byte value that is divisible by 4 which allows up to 64 encoders to share the bus.

By default, the node address is 0x54. Node addresses configurable via AMT Viewpoint™ or set at factory for specific configuration upon request.

Available RS485 Node Addresses (HEX)							
00	20	40	60	80	A0	C0	E0
04	24	44	64	84	A4	C4	E4
08	28	48	68	88	A8	C8	E8
0C	2C	4C	6C	8C	AC	CC	EC
10	30	50	70	90	B0	D0	F0
14	34	54*	74	94	B4	D4	F4
18	38	58	78	98	B8	D8	F8
1C	3C	5C	7C	9C	BC	DC	FC

*Default address

The node address serves also as the read position command which is why it will be referred to it as the base command. When the encoder sees a command on the RS485 it reads the first 6 bits to determine if it should be listening. If it sees its address, then it interprets the low two bits for the command.

Low two bits	Hex	Command
00	0x00	Read position
01	0x01	Read turns counter (multi-turn encoders only)
10	0x02	Set zero position
11	0x03	Reset encoder

For example, with the default encoder address (0x54), the following commands are available:

Byte	Command
0x54	Read position
0x55	Read turns counter (multi-turn encoders only)
0x56	Set zero position
0x57	Reset encoder

RS485 INTERFACE EXAMPLES

Single character commands

Read Position: <node_address>

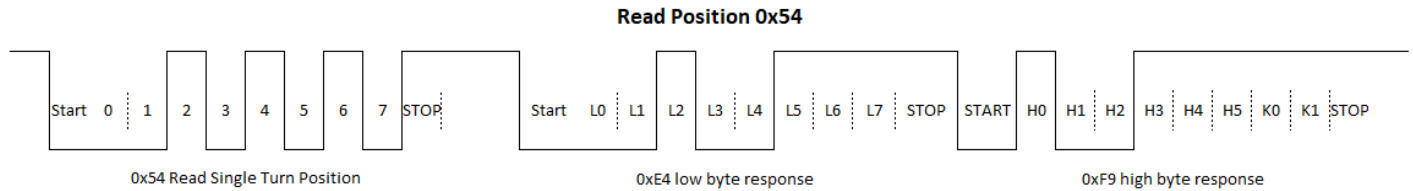

The read position command is the same as the node address which has a default value of 0x54 is sent and the response is received with the low byte first. After removing the checksum the result is 0x39E4. For a 14-bit encoder nothing else is required, the position is 14820 in decimal. However if this is a 12-bit encoder, the position must be shifted to the right 2 bits to throw away the low bits of the response. Therefore the position would be 3705 in decimal.

Read Turns (multi-turn encoders only): <node_address + 0x01>

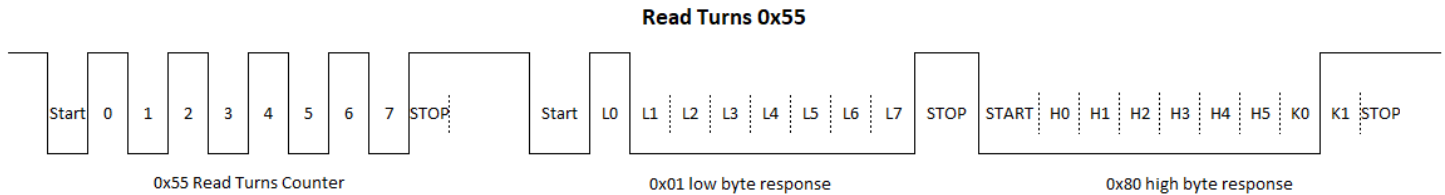

The turns counter command is <node_address + 0x01>. By default the turns counter command is 0x55. The encoder responds with the low byte first and includes check bits same as the read position command. The resulting number is a signed 14 bit number. The response above is showing 1 turn. This value is not retained between power cycles. After a power cycle, the value is reset to zero. The turn counter value is associated with the last read-position command. This ensures that the value does not change between commands. First, perform a position-read command, as shown above. Then read the turns counter.

Set Zero Position (single turn encoders only): <node_address + 0x02>

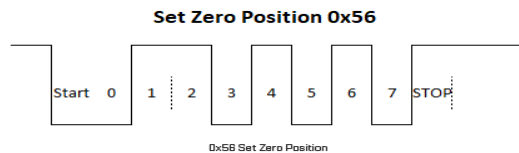

The zero set command is <node_address + 0x02>. By default we send 0x56. The encoder zero's the position and immediately resets.

Encoder Reset: <node_address + 0x03>

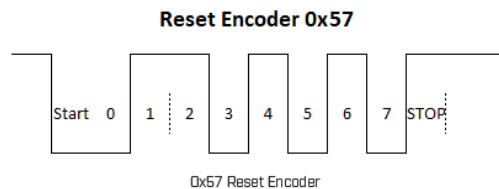

The reset command is <node_address + 0x03>. By default the command to reset the encoder is 0x57. The encoder performs and immediate reset.

PART NUMBER KEY

For customers that prefer a specific AMT24 configuration, please reference the custom configuration key below.

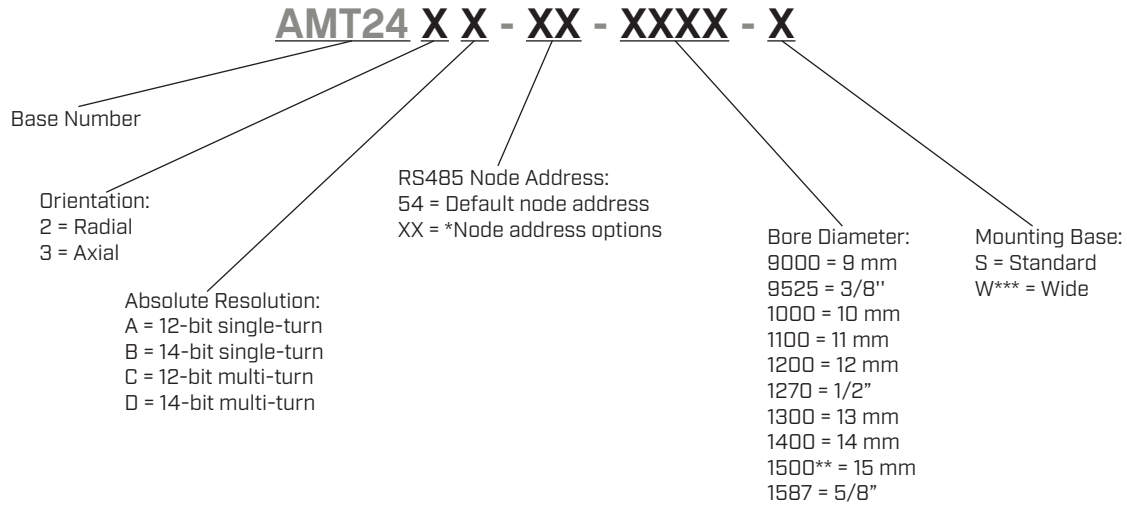

*Reference RS485 Interface Addressing section on page 3 for help selecting node address.

**15 mm bore diameter option only available as custom configuration.

***Wide base not included in kits.

AMT24-V KITS

In order to provide maximum flexibility for our customers, the AMT24 series is provided in kit form standard. This allows the user to implement the encoder into a range of applications using one sku#, reducing engineering and inventory costs. AMT24 kit includes all items shown below.

ORDERING GUIDE

AMT24XX-V

Orientation:
2 = Radial
3 = Axial

Absolute Resolution:
A = 12-bit single-turn
B = 14-bit single-turn
C = 12-bit multi-turn
D = 14-bit multi-turn

SHAFT ADAPTERS							
9 mm	3/8 in	10 mm	11 mm	12 mm	1/2 in	13 mm	14 mm
Light Blue	Orange	Purple	Gray	Yellow	Green	Red	Blue

AMT24	ALIGNMENT TOOL*	PLACEMENT TOOL	ALLEN WRENCH
Shaft adapter is not needed for 5/8" shaft			

*Alignment Tool comes pre-installed on all AMT24 Series.

ENCODER INTERFACE

CONNECTOR PINOUT	
#	Function
1 ¹	NC
2 ¹	NC
3	A
4	B
5 ¹	NC
6 ¹	NC
7	GND
8	+5 V

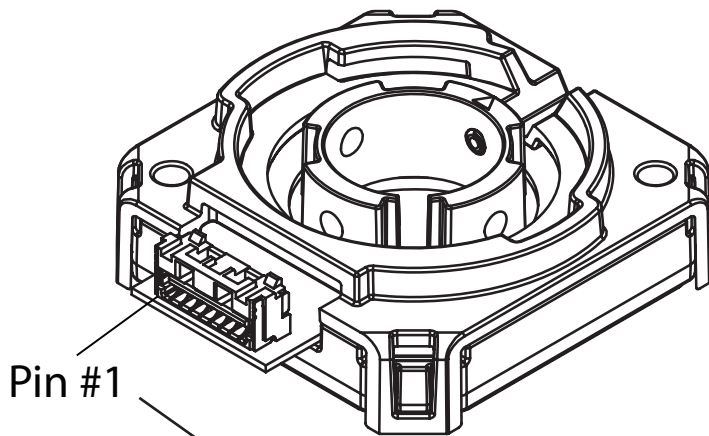
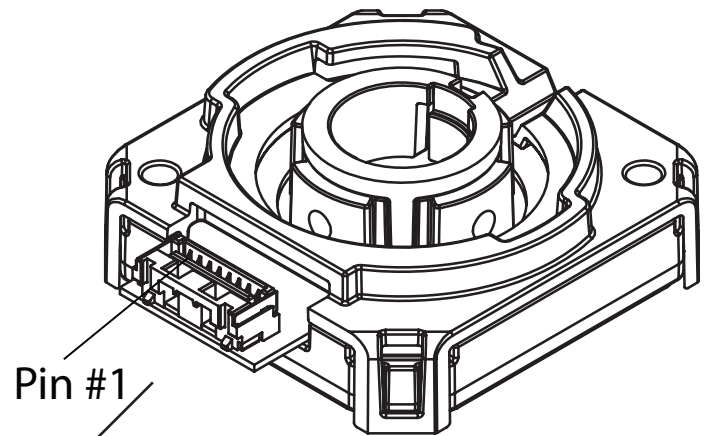
AMT242**AMT243**

Mating Connector:
Molex 502380-0800

- Notes:
1. Pins 1, 2, 5, & 6 are used for configuration only and should be left disconnected for RS485.
 2. Compatible with prototype cable AMT-08C-3-036 and programming cable AMT-PGRM-08C-1.

MECHANICAL DRAWING

units: mm
 tolerance:
 X.XX ±0.25 mm
 hole dia: ±0.08 mm

AMT242

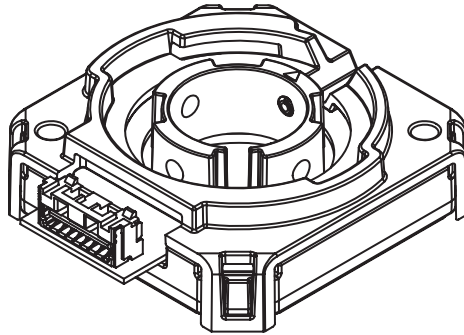

AMT243

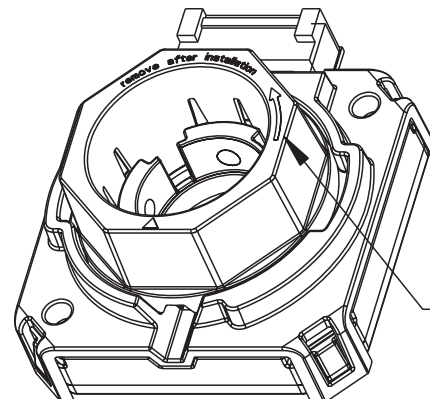
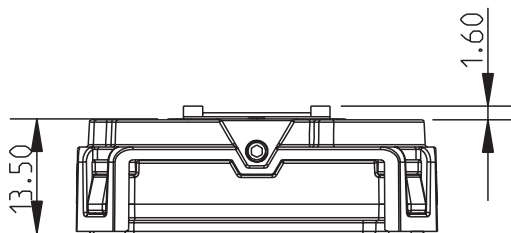
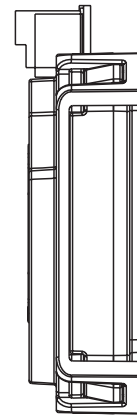
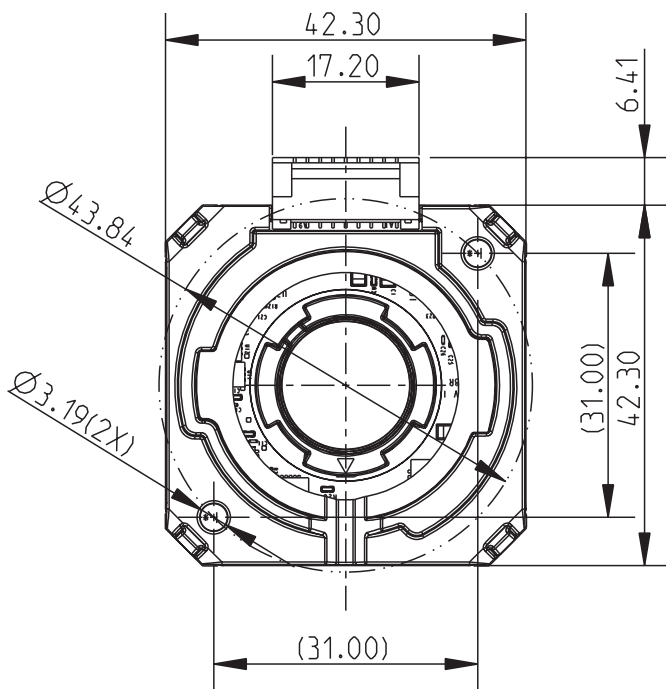
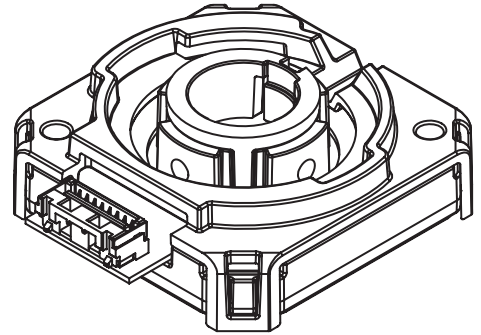

ALIGNMENT TOOL TO
 BE REMOVED AFTER
 INSTALLATION

MECHANICAL DRAWING (WIDE BASE)

units: mm
tolerance:
X.XX ±0.25 mm
hole dia: ±0.08 mm

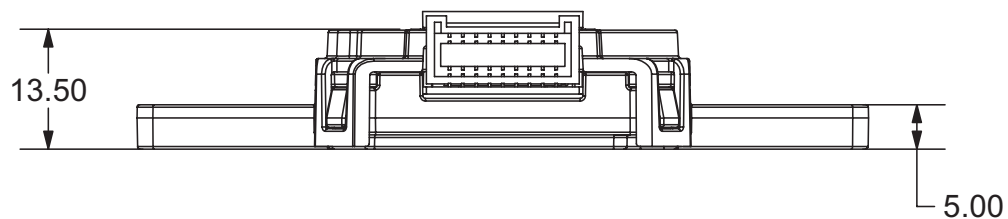
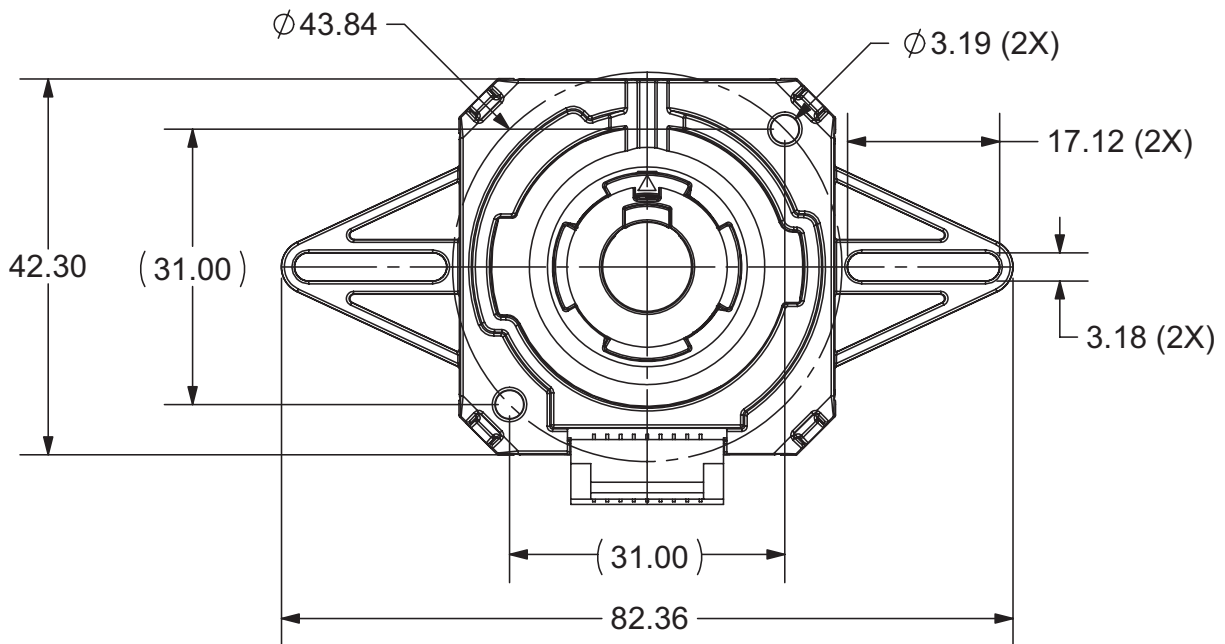
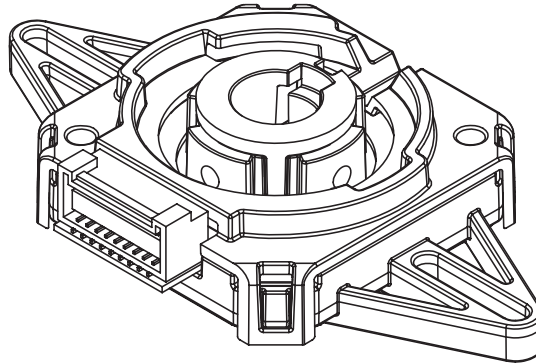

ASSEMBLY PROCEDURE

STEP 1

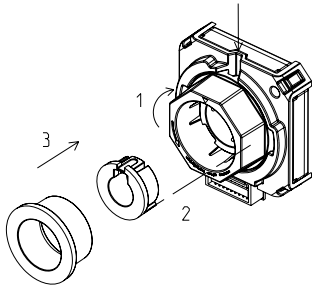

1. Begin by rotating the pre-installed alignment tool clockwise and completely to the right so that the pre-installed shaft set screw is visible.
2. Select the appropriately sized shaft adapter and insert it into the encoder making sure the adapter is properly aligned with the keyway in the metal hub. No adapter is needed for a 5/8" motor shaft.
3. Select the placement tool and insert it into the encoder. This placement tool holds the encoder's hub and shaft adapter in the proper position for installation onto the motor shaft.

STEP 2

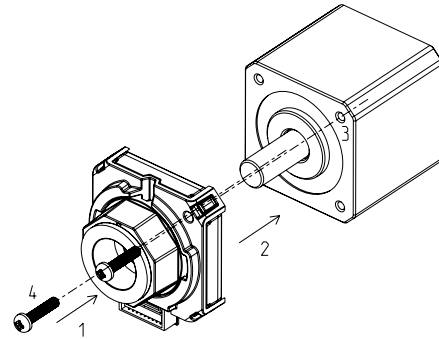

1. Slide the encoder onto the motor shaft applying force only to the placement tool to maintain proper alignment of the encoder's hub and shaft adapter.
2. Press until the encoder sits flush with the motor body.
3. Once in contact with the motor body, rotate the encoder until the mounting holes are aligned with the proper bolt circle.
4. Insert screws and fasten the encoder to the motor.

STEP 3

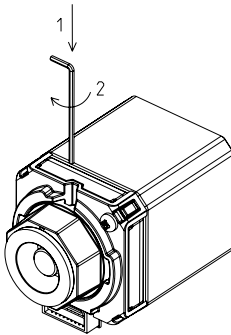

1. Insert the Allen Wrench into the notch on the top.
2. Tighten the shaft set screw to the recommended torque settings per the spec.

STEP 4

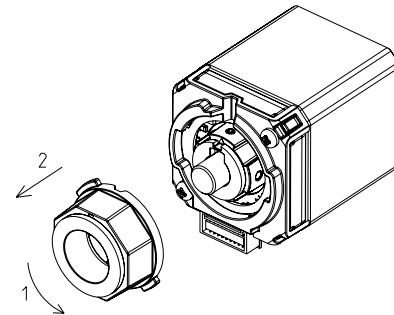

1. Rotate the placement tool and alignment tool counterclockwise until the tabs align with the openings.
2. Remove both tools from the encoder.
3. When installation is finished, the motor shaft should be rotating freely.

REVISION HISTORY

rev.	description	date
1.0	initial release	11/03/2023
1.01	updated datasheet	04/04/2024
1.02	CUI Devices rebranded to Same Sky	09/12/2024

The revision history provided is for informational purposes only and is believed to be accurate.



Same Sky offers a one (1) year limited warranty. Complete warranty information is listed on our website.

Same Sky reserves the right to make changes to the product at any time without notice. Information provided by Same Sky is believed to be accurate and reliable. However, no responsibility is assumed by Same Sky for its use, nor for any infringements of patents or other rights of third parties which may result from its use.

Same Sky products are not authorized or warranted for use as critical components in equipment that requires an extremely high level of reliability. A critical component is any component of a life support device or system whose failure to perform can be reasonably expected to cause the failure of the life support device or system, or to affect its safety or effectiveness.

[sameskydevices.com](https://www.sameskydevices.com)