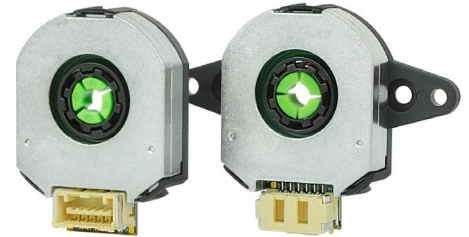

**SERIES:** AMT22 | **DESCRIPTION:** MODULAR ABSOLUTE ENCODER

**FEATURES**

- patented capacitive ASIC technology
- low power consumption
- full duplex Serial Peripheral Interface (SPI)
- 12 or 14-bit absolute position with multi-turn capability
- checksum bits for error detection
- configuration and firmware updates via AMT Viewpoint™ software
- digitally settable zero position (single-turn versions only)
- compact modular package with locking hub for ease of installation
- radial and axial cable connections
- -40 ~ 105°C operating temperature

**ELECTRICAL**

parameter	conditions/description	min	typ	max	units
power supply	VDD	3.8	5	5.5	V
start-up time <sup>1</sup>			200		ms
current consumption	with unloaded output		16		mA
input low level				0.8	V
input high level		2.0		5.5	V
output low level				0.8	V
output high level			3.3		V

Note: 1. Encoder must be stationary during start-up.

**ABSOLUTE POSITION CHARACTERISTICS**

parameter	conditions/description	min	typ	max	units
resolution	12 or 14-bit				
accuracy			0.2		degrees
absolute zero position	settable via AMT Viewpoint™ GUI or SPI (single-turn versions only)				
multi-turn	multi-turn and single-turn versions available				
turns counter <sup>2</sup>	signed binary number		14		bits
absolute position update rate	12-bit		25		μs
	14-bit		100		μs

Notes: 2. Multi-turn encoders only.

**MECHANICAL**

parameter	conditions/description	min	typ	max	units
motor shaft length		9			mm
motor shaft tolerance			NOM +0/-0.015		mm
weight			15.7		g
axial play				±0.3	mm
rotational speed (at each resolution)	12-bit position resolution			8,000	RPM
	14-bit position resolution			4,000	RPM

## ENVIRONMENTAL

parameter	conditions/description	min	typ	max	units
operating temperature		-40		105	°C
humidity	non-condensing			85	%
vibration	10~500 Hz, 5 minute sweep, 2 hours on each XYZ			5	G
shock	3 pulses, 6 ms, 3 on each XYZ			200	G
RoHS	yes				

## SERIAL INTERFACE

parameter	conditions/description	min	typ	max	units
protocol	Serial Peripheral Interface Mode 0				
frame size			8		bit
data rate				2	MHz
transceiver	SPI driven by PIC18F14K22 <sup>3</sup>				
$T_{CLK}$	data shifted to output buffer <sup>4</sup>	2.5			µs
$T_B$	time between bytes	2.5			µs
$T_{CS}$	time between reads	40			µs
$T_R$	time before CS can be released	3			µs

Notes: 3. See Microchip documentation for more details.  
4. This is the time it takes to load the most current position into the SPI buffer which prevents multiple read/response commands from being required.

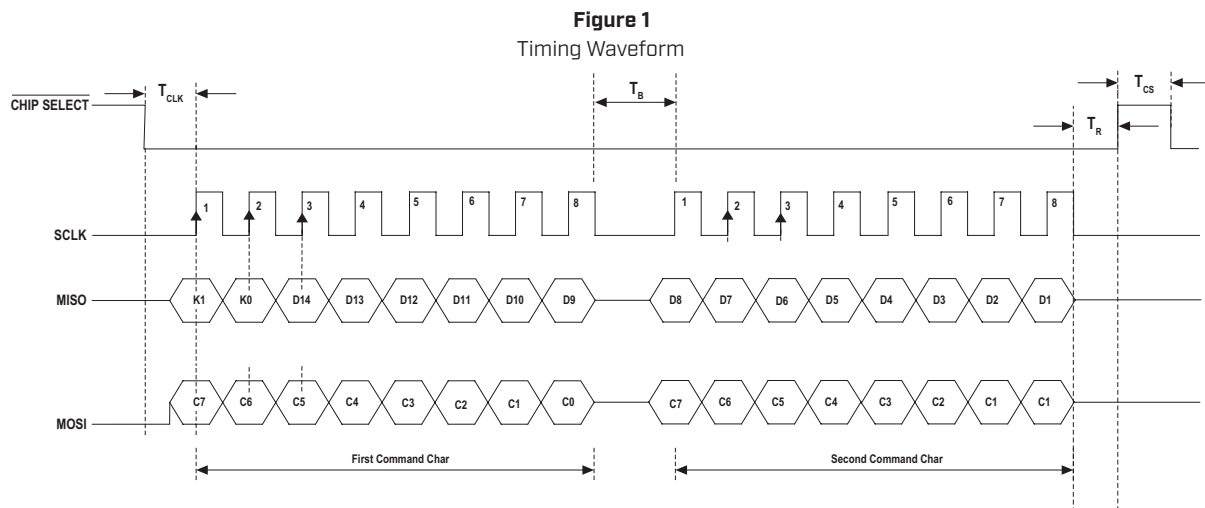

Values K1 and K0 in the response are checkbits. The checkbits are odd parity over the odd and even bits in the position response shown in the equation below. The checkbits are not part of the position, but are used to verify its validity. The lower 14 bits are the encoder position.

Example:

Full response: 0x61AB

14-bit position: 0x21AB (8619 decimal)

### Checkbit Formula

Odd:  $K1 = !(H5 \wedge H3 \wedge H1 \wedge L7 \wedge L5 \wedge L3 \wedge L1)$

Even:  $K0 = !(H4 \wedge H2 \wedge H0 \wedge L6 \wedge L4 \wedge L2 \wedge L0)$

From the above response 0x61AB:

Odd:  $0 = !(1 \wedge 0 \wedge 0 \wedge 1 \wedge 1 \wedge 1) = \text{correct}$

Even:  $1 = !(0 \wedge 0 \wedge 1 \wedge 0 \wedge 0 \wedge 0 \wedge 1) = \text{correct}$

For 12-bit applications L0 and L1 are always 0. Because the low two bits are 0, 12-bit data will need right-shifted two bits. The checkbit calculation remains the same and unaffected.

## SERIAL INTERFACE (CONTINUED)

### Commands:

#### Read Position

Hex command sequence: 0x00 0x00

The command to read position is 0x00, 0x00 because the encoder will always respond with the current position when SPI is accessed. The encoder observes the second byte for extended commands.

### Extended Commands:

#### Reset Encoder

Hex command sequence: 0x00 0x60

The encoder responds with the current position over the transmission then immediately resets. Observe the power on time when using this command. Encoder must be stationary to power back on.

#### Set Zero Point (single-turn encoders only)

Hex command sequence: 0x00 0x70

The encoder responds with the current position over this transmission then saves the current position into memory and performs a reset. Encoder must be stationary for this command. Observe the power on time when using this command.

#### Read Turns (multi-turn encoders only)

Hex command sequence: 0x00 0xA0 0x00 0x00

The encoder responds with position during the transfer of the first two bytes. The encoder responds with the current turn value in the second two bytes. The resulting number is a signed 14 bit number. This value is not retained between power cycles. After a power cycle, the value is reset to zero.

Chip select must be held low for the entire four byte transfer, and  $T_{\text{b}}$  should be observed between each byte.

## AMT VIEWPOINT™ OPERATION

The AMT22 encoder operates in two modes: programming, and SPI mode. To enter programming mode for use with AMT Viewpoint™ the slide on the bottom of the encoder must be moved to the programming position. Slide the switch to the left position before connecting encoder to AMT Viewpoint™. Once configuration in AMT Viewpoint™ is completed, disconnect encoder and return switch to the standard run mode position before connecting encoder to system. Switch must be in proper mode for programming or SPI before power is connected to device.

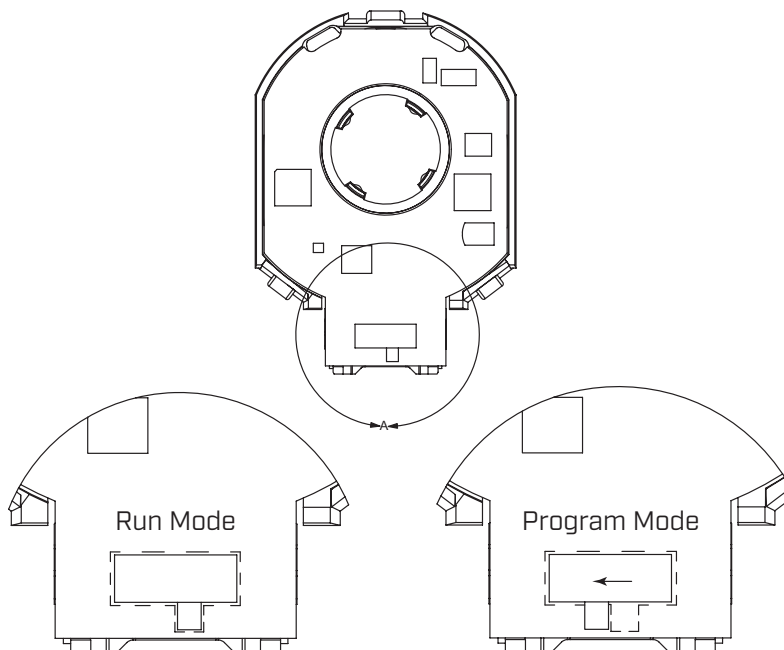

## PART NUMBER KEY

For customers that prefer a specific AMT22 configuration, please reference the custom configuration key below.

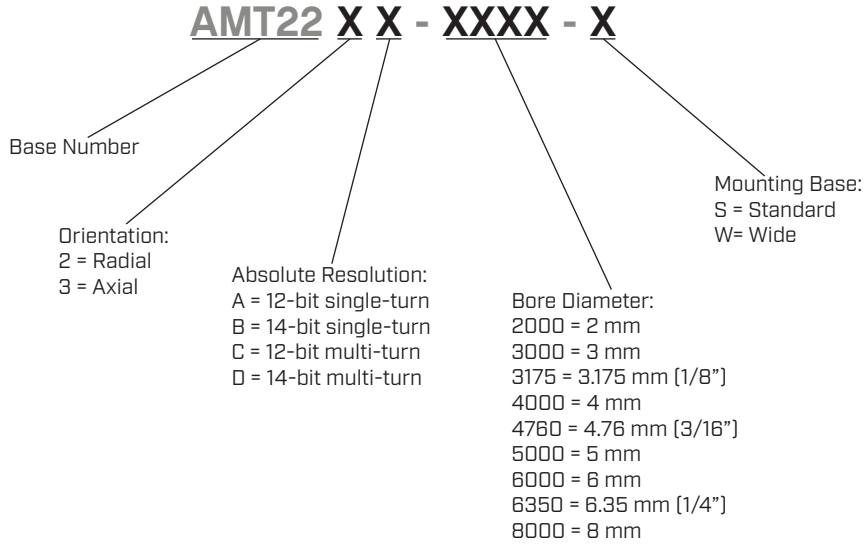

## AMT22-V KITS

In order to provide maximum flexibility for our customers, the AMT22 series is provided in kit form standard. This allows the user to implement the encoder into a range of applications using one sku#, reducing engineering and inventory costs.

### ORDERING GUIDE

**AMT22XX-V**

**Orientation:**  
2 = Radial  
3 = Axial

**Absolute Resolution:**  
A = 12-bit single-turn  
B = 14-bit single-turn  
C = 12-bit multi-turn  
D = 14-bit multi-turn

SLEEVES								
2mm	3mm	1/8 inch (3.175mm)	4mm	3/16 inch (4.76mm)	5mm	6mm	1/4 inch (6.35mm)	8mm
Light Sky Blue	Orange	Purple	Gray	Yellow	Green	Red	Snow	Blue

BASE	WIDE BASE	TOP COVER	SHAFT ADAPTER	TOOL A	TOOL C

## ENCODER INTERFACE

PINOUT CONNECTOR	
#	Function
1	+5 V
2	SCLK
3	MOSI
4	GND
5	MISO
6	CHIP SELECT

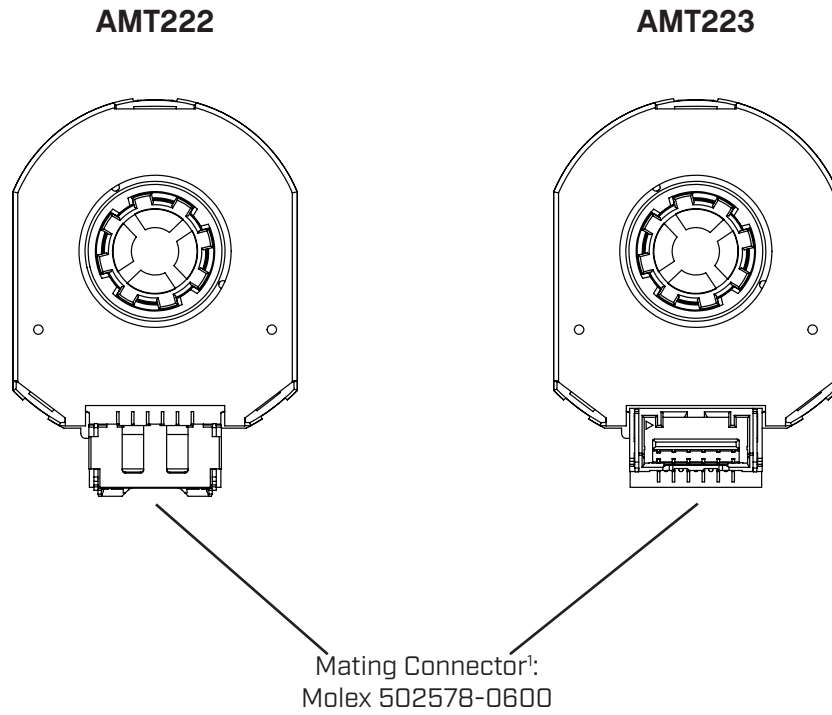

Notes: 1. Compatible with prototype cable AMT-06C-1-036 and programming cable AMT-06C-1-036-USB.

## MECHANICAL DRAWING

### AMT222

units: mm  
tolerance: ±0.1

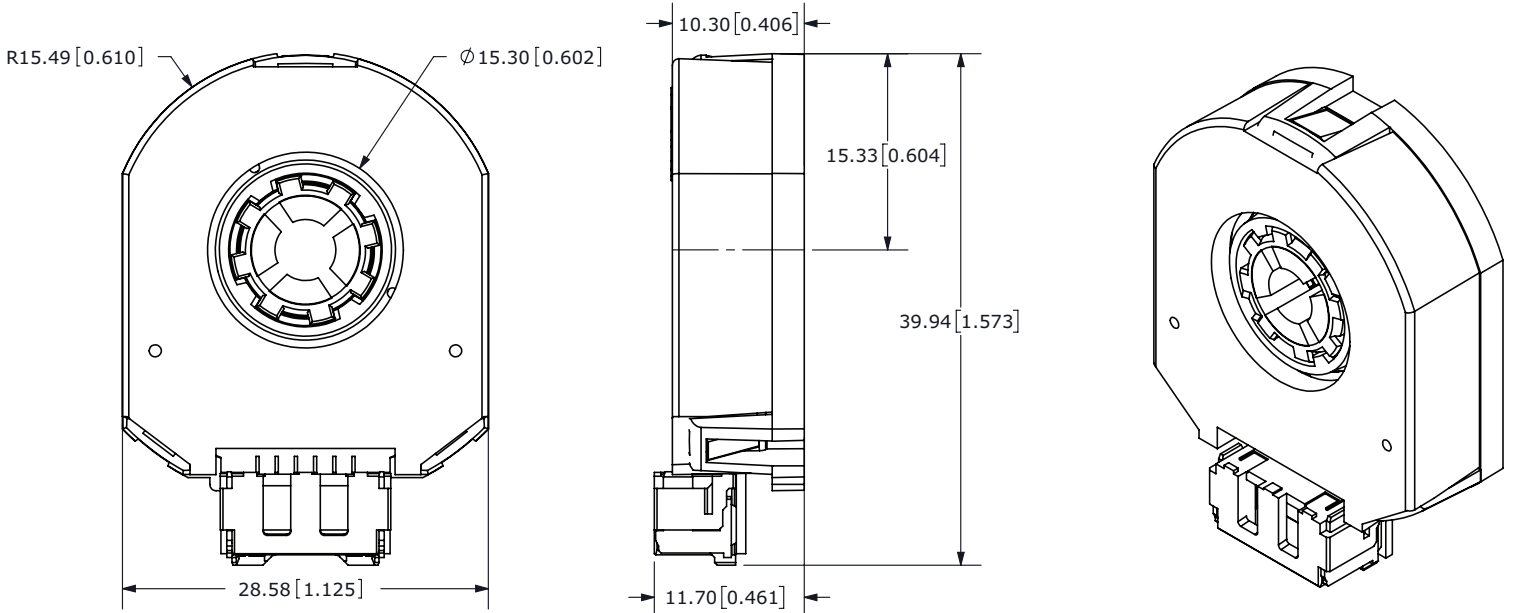

### AMT223

units: mm  
tolerance: ±0.1

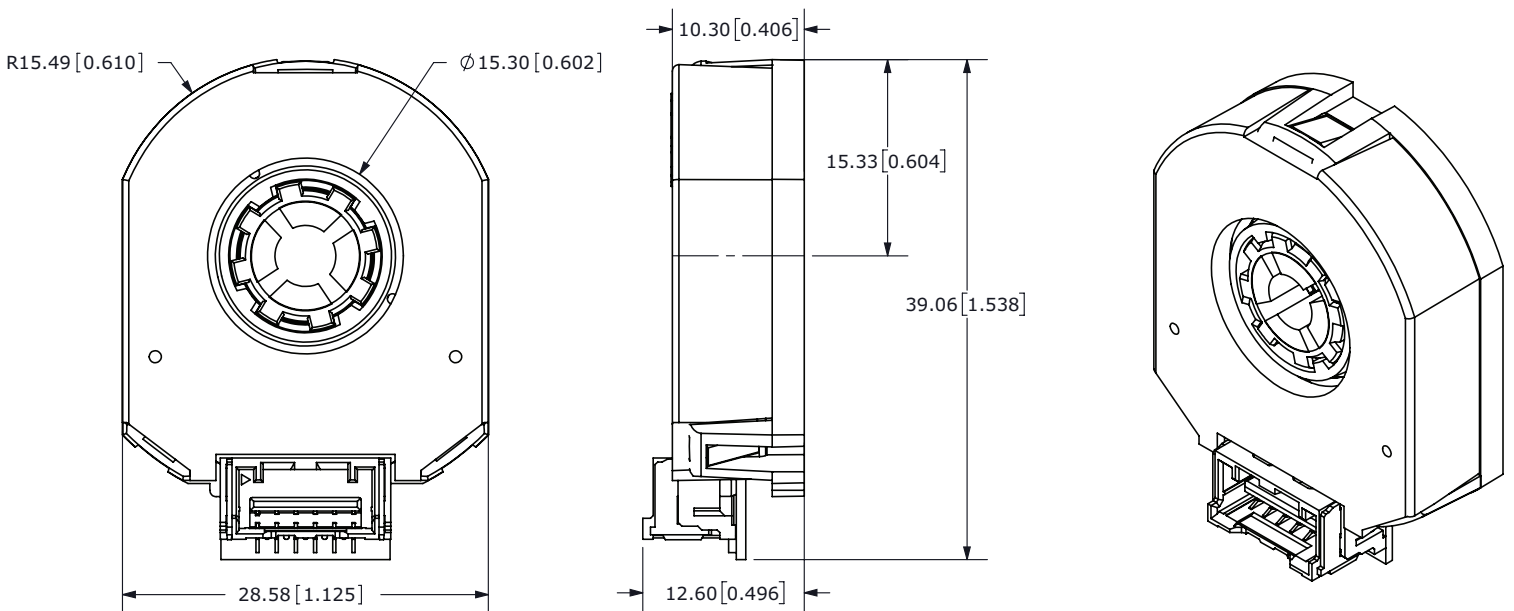

## MECHANICAL DRAWING (CONTINUED)

### MOUNTING HOLE PATTERNS

#### STANDARD BASE

units: mm[inch]  
tolerance: ±0.1

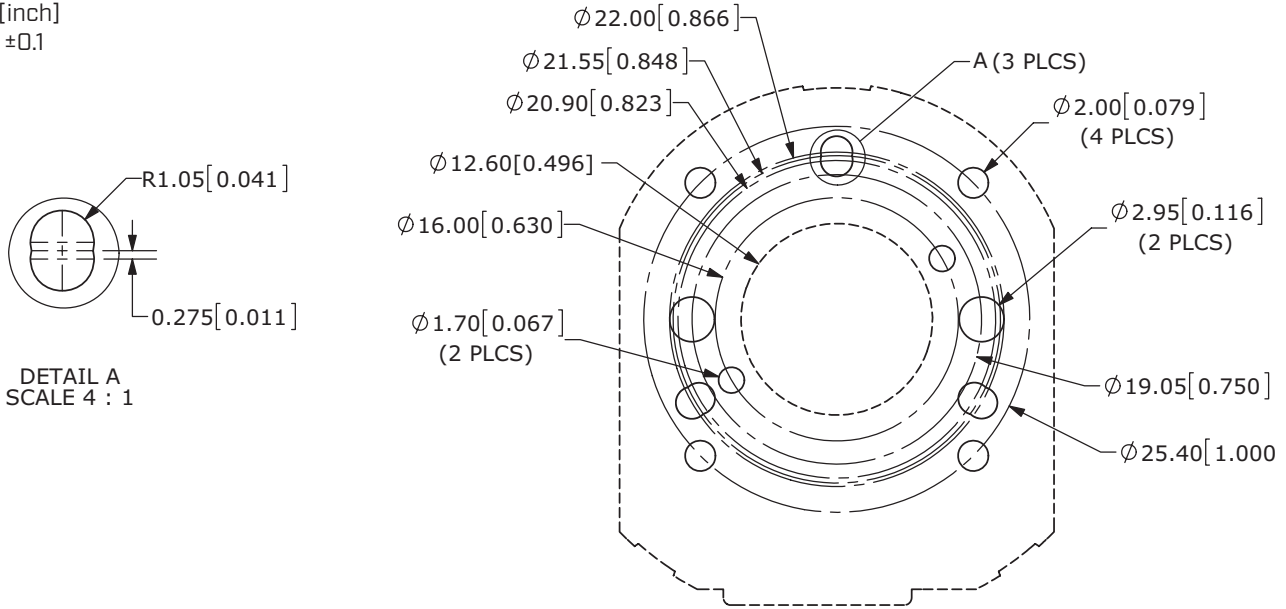

#### WIDE BASE

units: mm[inch]  
tolerance: ±0.1

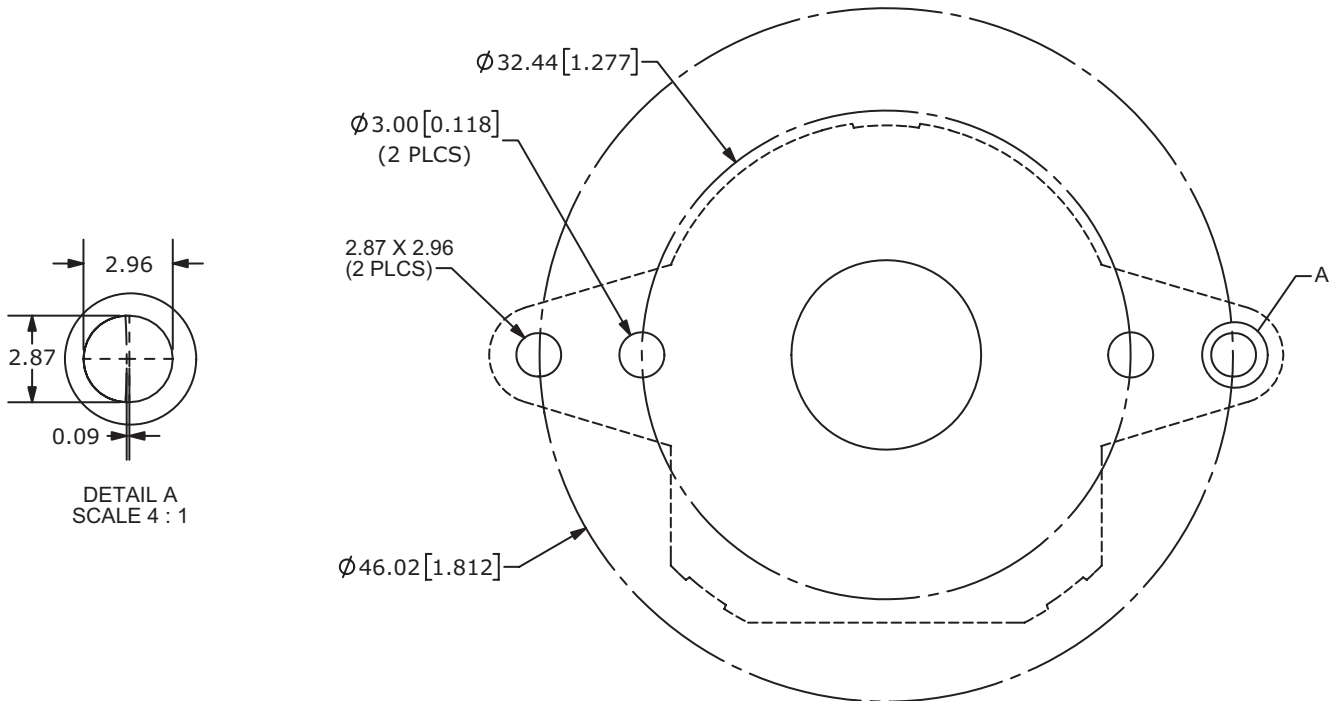

## ASSEMBLY PROCEDURE

### STEP 1

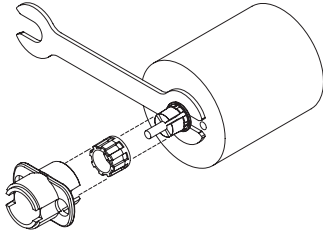

1. Insert Tool A as a spacer that defines the distance to the mounting surface.
2. Slide appropriate sized Sleeve over shaft all the way down to Tool A.
3. Slide Shaft Adaptor over Sleeve.
4. Use Tool C to press Shaft Adaptor over Sleeve [ensure Shaft Adaptor and Tool C spline alignment] until flush with Tool A.

### STEP 2

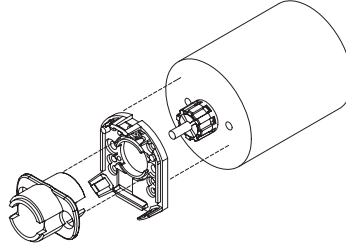

1. Remove Tools A and C.
2. Place Base on motor, with Tool C used as a centering tool.

### STEP 3

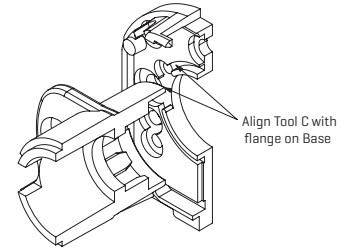

1. Align Tool C with flange on Base.
2. Slide Base and Tool C onto motor, centering onto the Shaft Adaptor.

### STEP 4

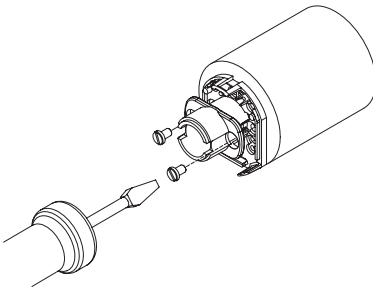

1. Fasten the Base on the motor (Tool C may need to be rotated to allow for some mounting configurations).
2. Remove Tool C.

### STEP 5

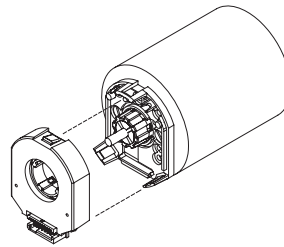

1. Snap the Top Cover onto the Base, carefully observing that the teeth of the Shaft Adaptor align with the grooves in the hub. \*
- \* We recommend no more than three cycles of mounting and removal of the AMT top cover base. Multiple cycles of mounting and removing the top cover can cause base fatigue over time and affect encoder performance.

### STEP 6

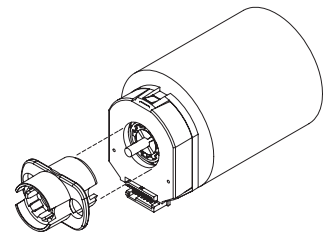

1. Make sure the snaps are fully engaged by pressing on the Hub with the reverse side of Tool C.
2. When assembly is finished, the Shaft Adaptor, Sleeve and Rotor Hub should all be flush with the Motor Shaft rotating freely.



## REVISION HISTORY

rev.	description	date
1.0	initial release	12/14/2018
1.01	updated $T_{CLK}$ and $T_{CS}$ values	06/26/2019
1.02	updated current consumption value	07/17/2019
1.03	added start-up time details	08/12/2019
1.04	brand update	11/21/2019
1.05	added multi-turn versions, updated start-up details	08/05/2021
1.06	updated datasheet	02/22/2022
1.07	logo, datasheet style update	08/05/2022
1.08	added multi-turn interface details	05/11/2023
1.09	CUI Devices rebranded to Same Sky	09/12/2024

The revision history provided is for informational purposes only and is believed to be accurate.



Same Sky offers a one (1) year limited warranty. Complete warranty information is listed on our website.

Same Sky reserves the right to make changes to the product at any time without notice. Information provided by Same Sky is believed to be accurate and reliable. However, no responsibility is assumed by Same Sky for its use, nor for any infringements of patents or other rights of third parties which may result from its use.

Same Sky products are not authorized or warranted for use as critical components in equipment that requires an extremely high level of reliability. A critical component is any component of a life support device or system whose failure to perform can be reasonably expected to cause the failure of the life support device or system, or to affect its safety or effectiveness.

[sameskydevices.com](https://www.sameskydevices.com)