

## Product Change Notice (PCN)

**Date:** 6/24/2024

**PCN Number:** PCN-0531109R-01

To Our Customers:

We appreciate your use of our products. Our commitment in maintaining and improving processes is demonstrated by plans to enhance our product quality, reliability, and manufacturability. The purpose of this notice is to inform you of a product change.

Product(s) Affected: *CBL-A31-C31-05BP, CBL-A31-C31-05BT, CBL-A31-C31-05WP, CBL-A31-C31-05WT, CBL-A31-C31-05GP, CBL-A31-C31-05GT, CBL-A31-C31-10BP, CBL-A31-C31-10BT, CBL-A31-C31-10WP, CBL-A31-C31-10WT, CBL-A31-C31-10GP, CBL-A31-C31-10GT, CBL-A31-C31-15BP, CBL-A31-C31-15BT, CBL-A31-C31-15WP, CBL-A31-C31-15WT, CBL-A31-C31-15GP, CBL-A31-C31-15GT, CBL-A31-C31-20BP, CBL-A31-C31-20BT, CBL-A31-C31-20WP, CBL-A31-C31-20WT, CBL-A31-C31-20GP, CBL-A31-C31-20GT*

Reason(s) for Change: *Modified Design.*

Description of Change: *A more passive resistor was implemented on the A5 pin. Voltage and current listing updated.*

*Before.*

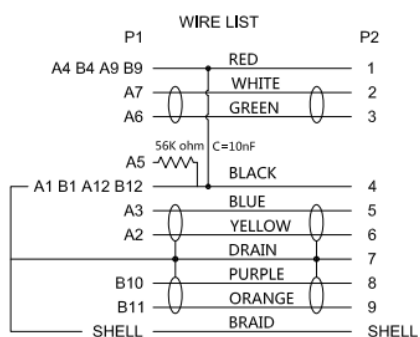

*After.*

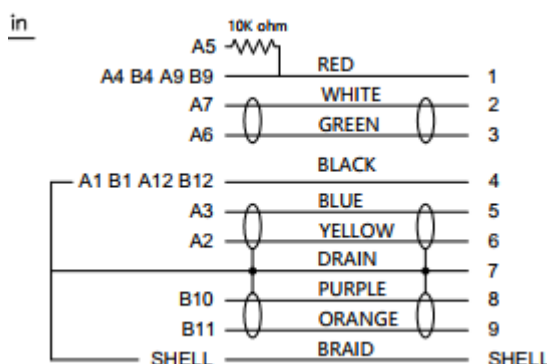

Affected Date Code: *June 24, 2024*

Product Availability: *Any production orders marked June 24, 2024, or later will have the new design implemented.*

F-723-001

Revision: A



PCN Approval:

Operations/Quality

*Robert Aguirre*

---

Product Management

*Meredith Aguirre*

---