

Product Change Notice (PCN)

Date: 12/06/2024

PCN Number: PCN-0452309R

To Our Customers:

We appreciate your use of our products. Our commitment in maintaining and improving processes is demonstrated by plans to enhance our product quality, reliability, and manufacturability. The purpose of this notice is to inform you of a product change.

Product(s) Affected: *UJC-VP-3-SMT-TR*

Reason(s) for Change: *Modified production process to reduce risk of plastic flash failures. Modified design. New Machine & mold.*

- Description of Change: *The corners of the matting face of the shell are less radial. New dimensional measure is provided for change. No dimensions defined within the previous version of the datasheet were subject to change. Terminal feet material upgraded to matte gold plating. Retention springs added for improved mating. Cosmetic changes to the shell.*

Before.

After.

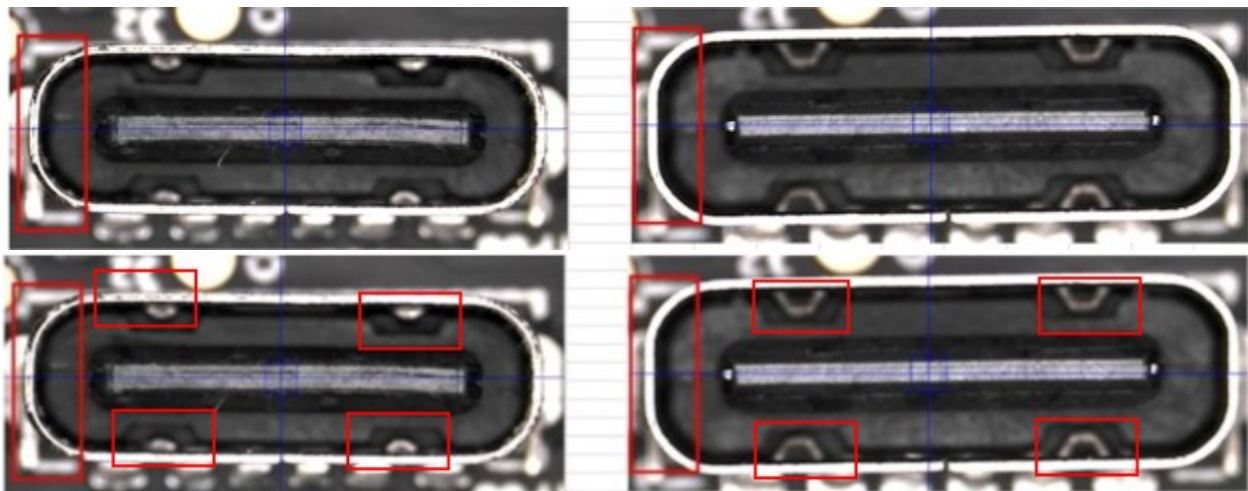

same sky

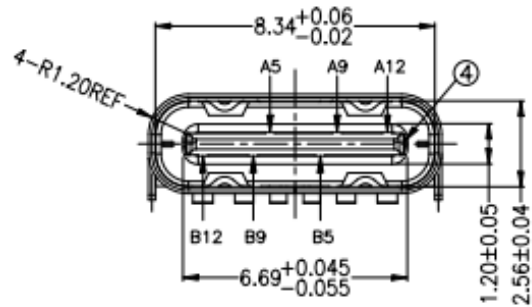
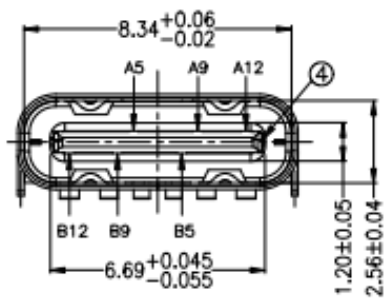
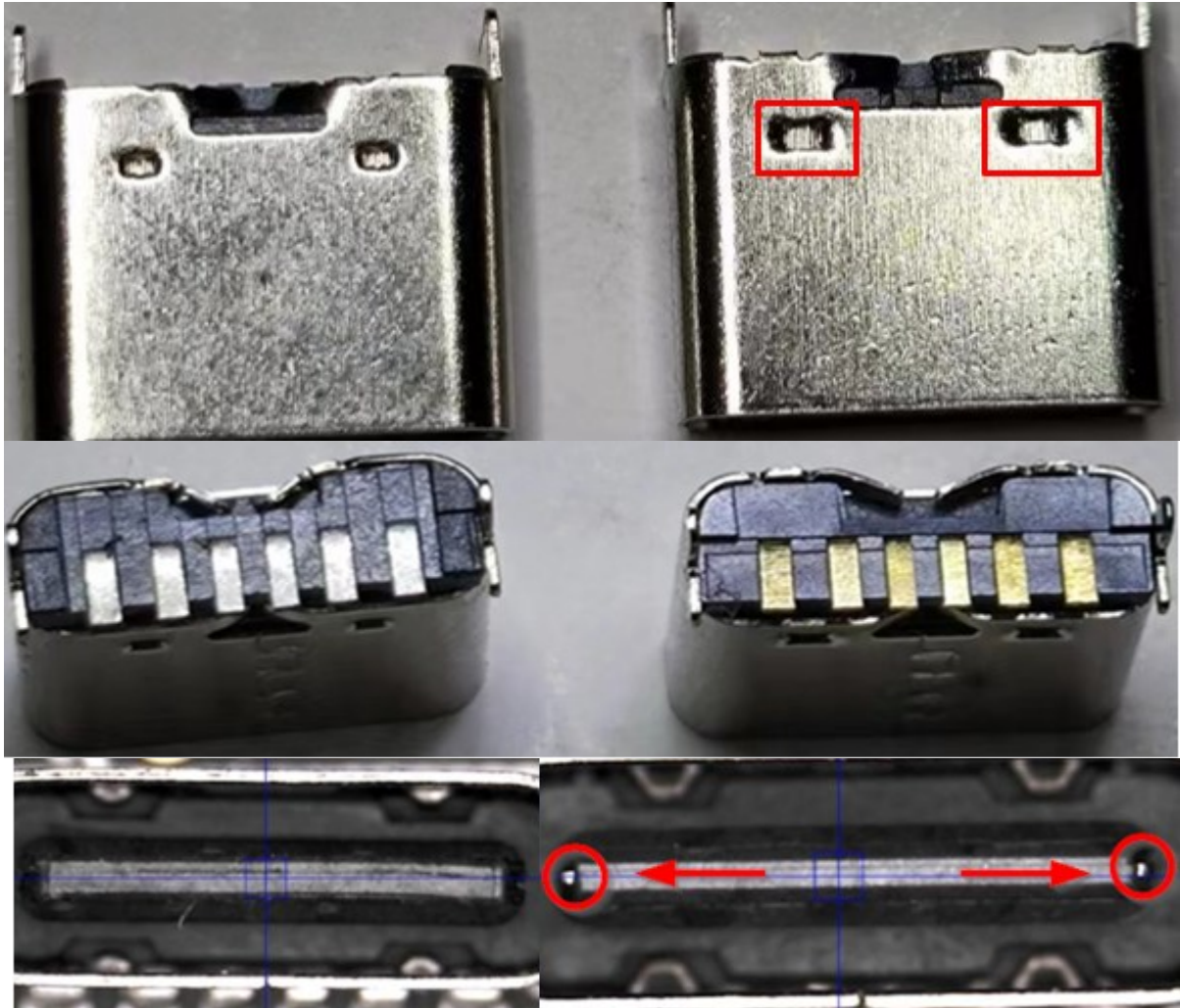

Affected Date Code: *July 6, 2024*

Product Availability: *Any production orders marked July 6, 2024, or later will have the new design implemented. No last time buys available.*

F-723-001

Revision: B



PCN Approval:

Operations/Quality

A handwritten signature in black ink, appearing to read 'Robert Griffin', is written above a horizontal line.

Product Management

A handwritten signature in black ink, appearing to read 'Michael Adams', is written above a horizontal line.